

# SKALS

*- we'll sort it out!*

# Manual

VTX Washer manual Rev 0  
VTX1425 - VTX1437 - VTX1450



A/S SKALS MASKINFABRIK  
HOVEDGADEN 56  
DK-8832 SKALS, DANMARK  
Tlf.: +45 87 25 62 00  
Fax: +45 86 69 49 99  
E-mail: [Skals@skals.DK](mailto:Skals@skals.DK)  
<http://www.skals.DK/>



1	Index	
1	Index .....	2
2	Introduction .....	3
3	Safety .....	4
3.1	Pictograms.....	4
4	General .....	5
4.1	Inlet.....	6
4.2	Washer drum .....	6
4.3	Outlet damper .....	6
4.4	Support, transmission and motors.....	7
4.5	Outlet conveyor.....	8
4.6	Bottom outlet valves.....	8
5	Extra equipment .....	10
5.1	Conveyor for floating plant residues.....	10
5.2	Internal sprinkling.....	11
6	Before operation.....	12
6.1	Installation .....	12
6.2	Electrical connection .....	13
6.3	Air pressure connection .....	13
7	Control and operation.....	14
7.1	General.....	14
7.2	Main screen .....	14
7.3	Settings for WASH.....	15
7.4	Overview.....	18
7.5	ALARMS.....	19
7.6	MANUAL OPERATION.....	19
7.7	Language settings – from the settings menu.....	20
8	Service and maintenance .....	21
8.1	Bearings .....	21
8.2	Gearbox.....	21
8.3	Conveyor belts.....	21
8.4	Cleaning .....	22

9	Transport.....	22
10	Specifications.....	23
11	Spare parts .....	24
12	Electric wiring diagram (valid for 3x400V +N +PE) .....	27
13	EU Declaration of Conformity.....	28

## 2 Introduction

Read this manual well before taking the machine into operation.

The machine is designed for washing root vegetables as potatoes, carrots and similar.

The machine is not suitable for washing products of a size less than 15mm diameter.

If the machine is used for washing consumer vegetables, the outfeed belt can be delivered as food suitable.

Inlet and washing barrel is from stainless steel.

The machine can be operated in the temperature range of 0 to +40°C.

Type plate and the CE marking plate is situated on the control panel.

### 3 Safety

Operating personnel must wear normal tight fit clothing. Loose fit clothing can jeopardise the workers safety.

#### 3.1 Pictograms

The machine can be equipped with two different pictograms.

#### Warnings



**Danger rotating parts.**

Avoid to get in contact with moving parts on the machine.



**Crushing hazard.**

Avoid to get in contact with moving parts on the machine.

#### Instructions



**Lifting hook**

Shows where to hook the machine before lifting.



**Strap attachment**

Shows where to strap the machine during transport.

## 4 General

Machine description (standard model)

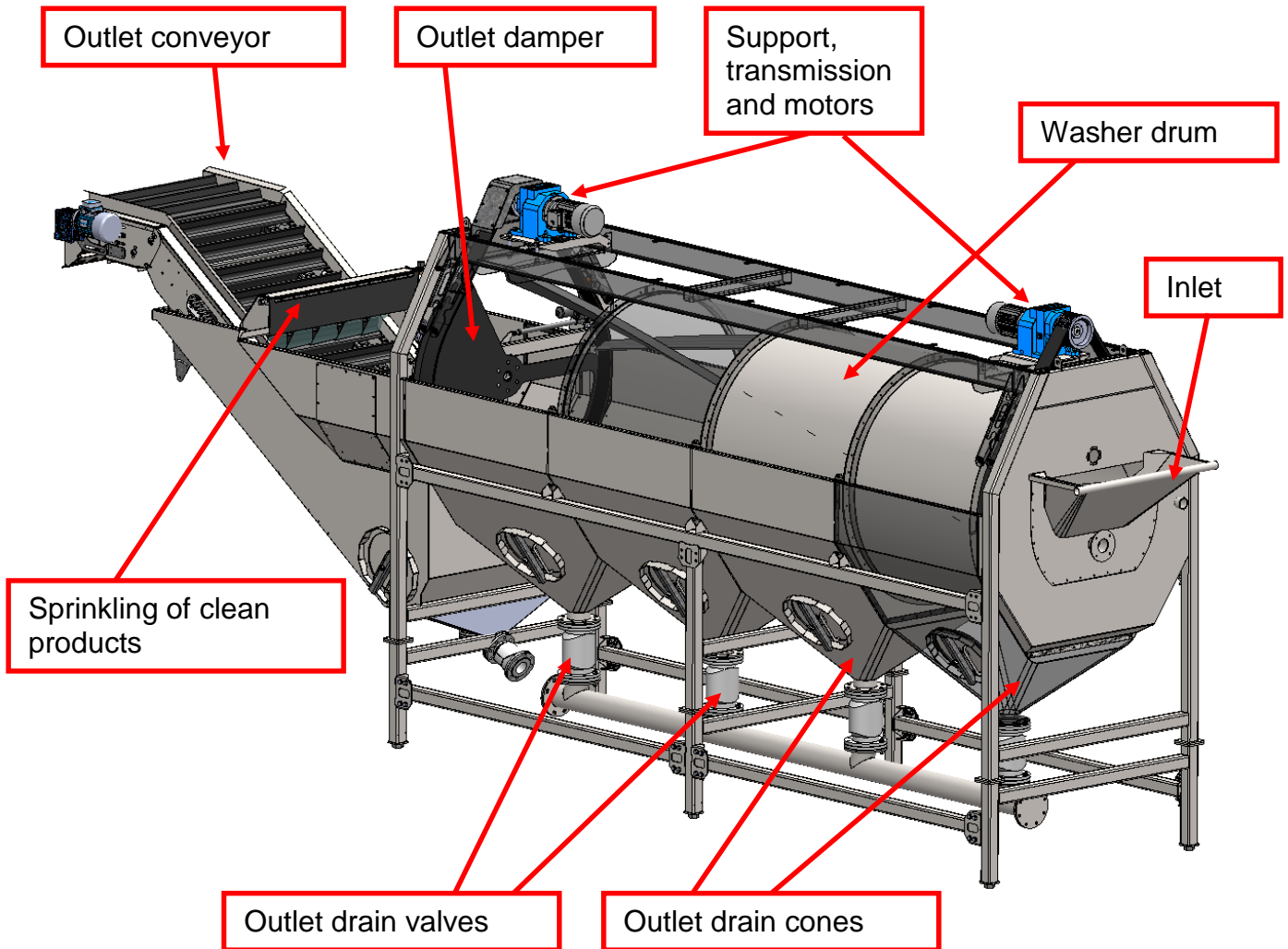

SKALS VTX washing machine is built with modular design. The machine can be delivered with 2, 3 or 4 sections. The washing drum has a diameter of 1400mm. That ensures high capacity and efficient gentle washing of vegetables.

The Standard edition is delivered with pintle belt or with a Food suitable PVC-belt with slitted cleats and perforated belt for optimal water drainage.

#### 4.1 Inlet

The washer inlet is from stainless steel.

**Water inlet** is used for water filling into the washer. Normally clean water or recycled water from a cleaning system is used.

**The machine interface** has two purposes. The interface pipe is hollow and here can be added water flow to the inlet to avoid dirt to get stuck.

SKALS conveyors comes with a special bracket that fits the machine interface pipe.

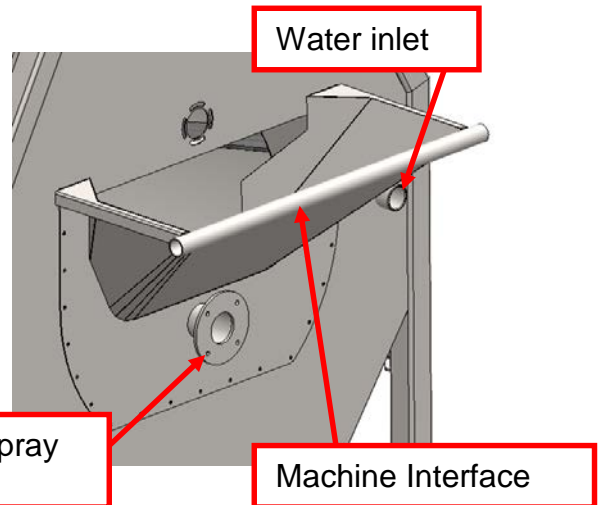

**Emptying spray nozzle** can be connected to a pump, spraying water into the washer drum for an efficient emptying of the drum. Water is normally recirculated from the outlet section to create optimal flow.

#### 4.2 Washer drum

The washer drum is from stainless steel. The drain perforation is optimized for achieving the best removal of dirt and soil. The perforation is with countersink holes for a very gentle wash of the vegetables. Long holes in the perforation are important for not damaging carrots during wash.



#### 4.3 Outlet damper

The outlet damper position (here shown 100% open) is set on the panel. The damper limits the flow of vegetables out of the machine for better wash or for higher capacity. At emptying the washing drum, the damper opens 100% for complete emptying of the machine.

The damper is controlled by the electrical actuator step less between 0-100% (corresponding 90deg turn).

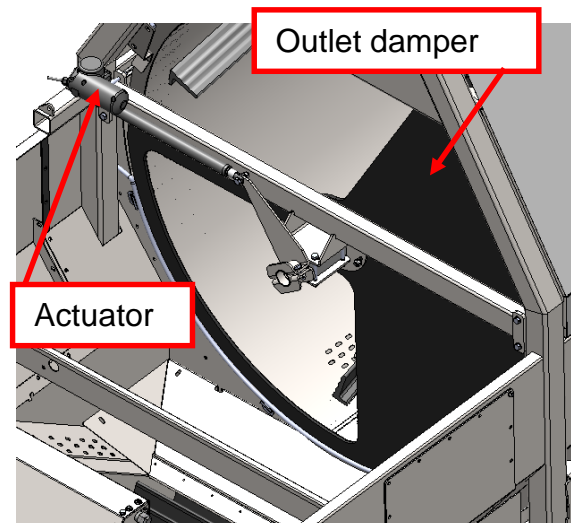

#### 4.4 Support, transmission and motors

The washer barrel is suspended by the transmission belts.

By adjusting the motor support bolts, the barrel is lifted and adjusted into center of the machine.

The radial support rollers are adjusted to full contact with the barrel.

When the barrel is hanging unloaded there must be full contact with all support rollers.

Axial support rollers are controlling the barrel movement in axial direction.

The barrel outlet flange must be adjusted close to the outlet damper without direct contact.

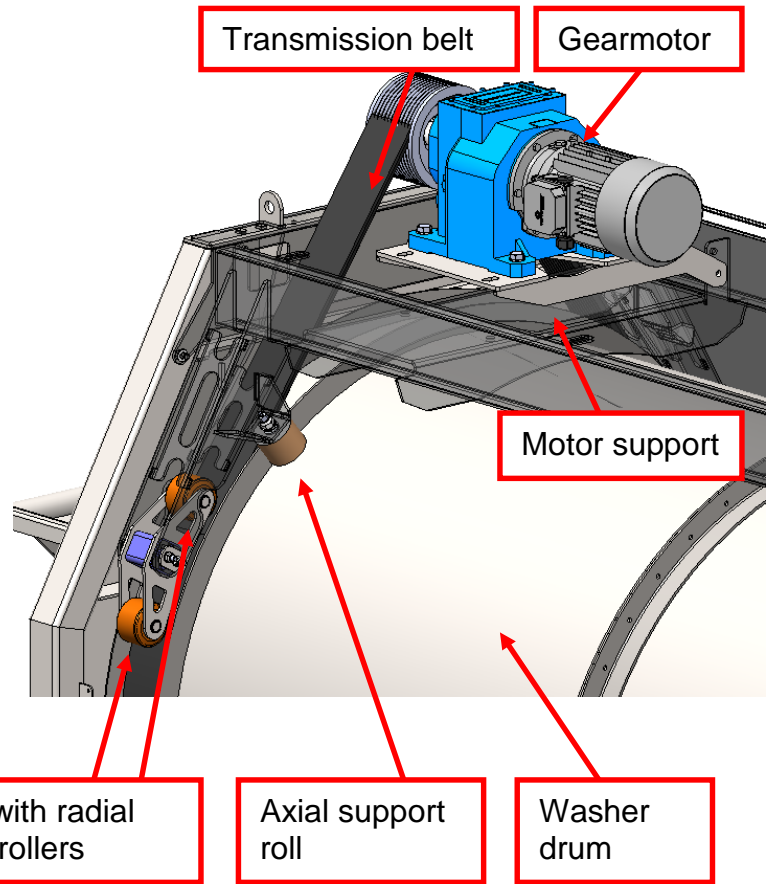

#### 4.5 Outlet conveyor

The outlet conveyor can be supplied as a pintle belt or food suitable pvc-belt. Both types drains the water from clean wet products back to the washer and conveys the clean products on to the next process. A sprinkler system over the outlet belt is rinsing the clean products for dirt.

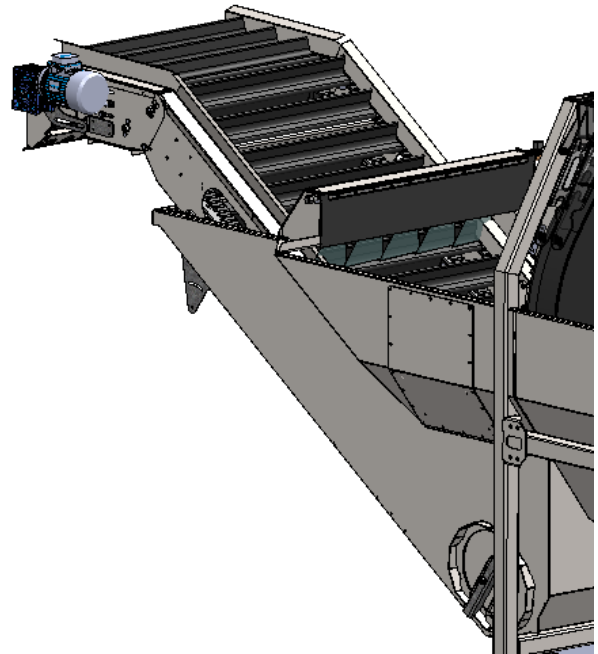

#### 4.6 Bottom outlet valves

The outlet valves are a part of the dirt setting system. Dirt from the setting cones are washed out through the valves according to a preset cycle in the control. Waste water is led to water purification or sewer.

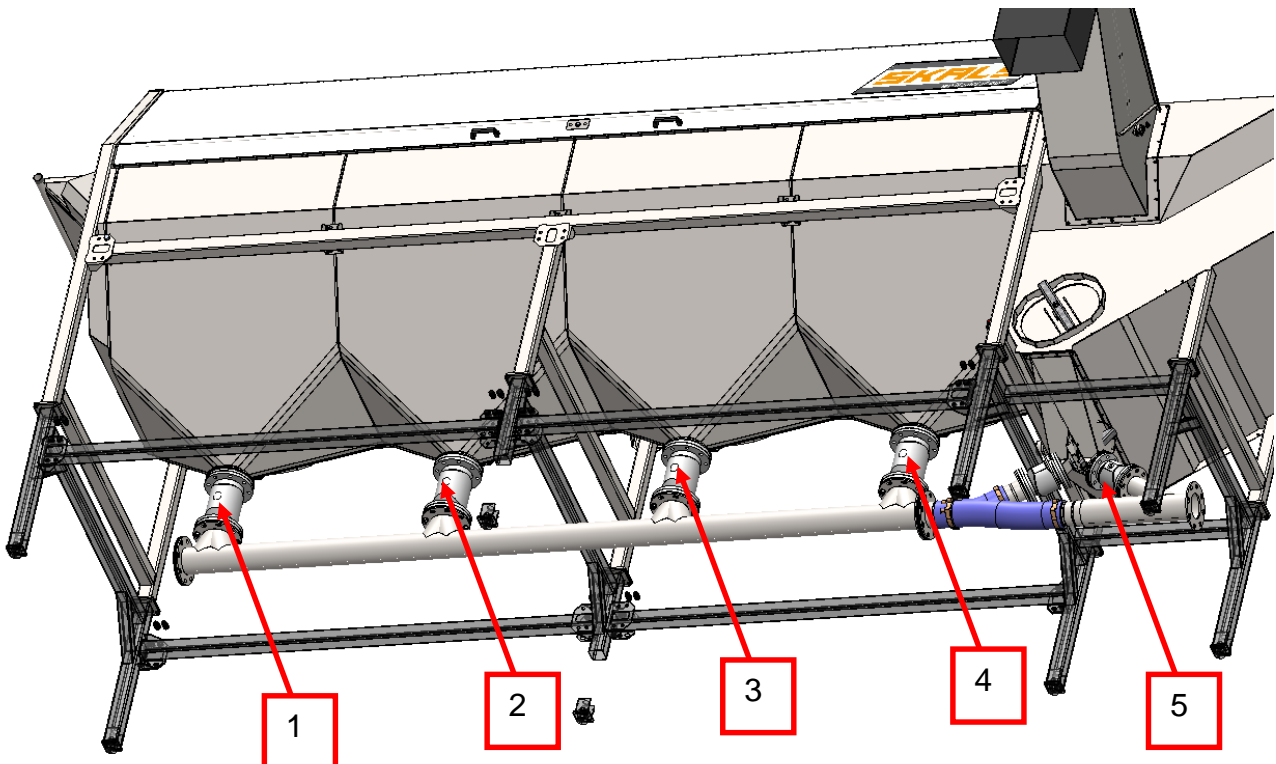



The valves are of the pinch valve type. The valves are activated by air pressure. The valve is “normally open”. That means closed under pressure. The valve squeezes the media. If plant residues gets stuck, the valve closes anyway by squeezing around the foreign.

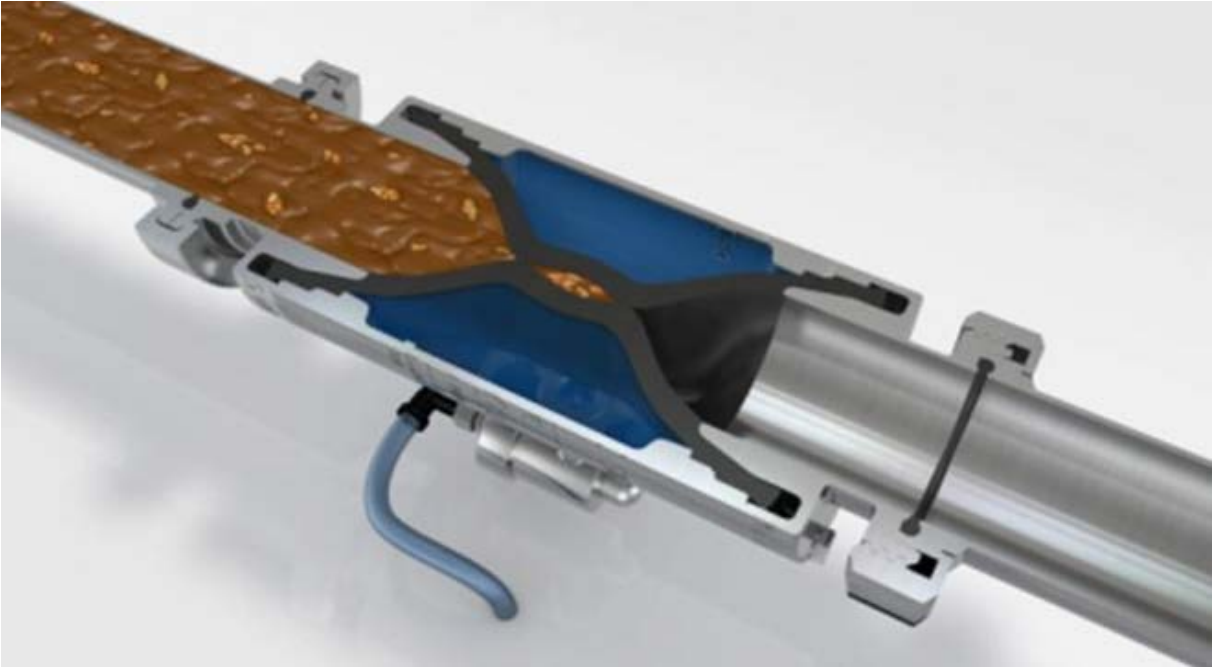

## 5 Extra equipment

### 5.1 Conveyor for floating plant residues

The conveyor for floating residues is extra equipment. It is preferable where potatoes are grown the season after corn. Corn roots float on the water, and are drawn with the clean vegetables if not removed. The conveyor is also suitable for removing "hollow" potatoes and other floating plant residues. The operation interval is set on the main panel.

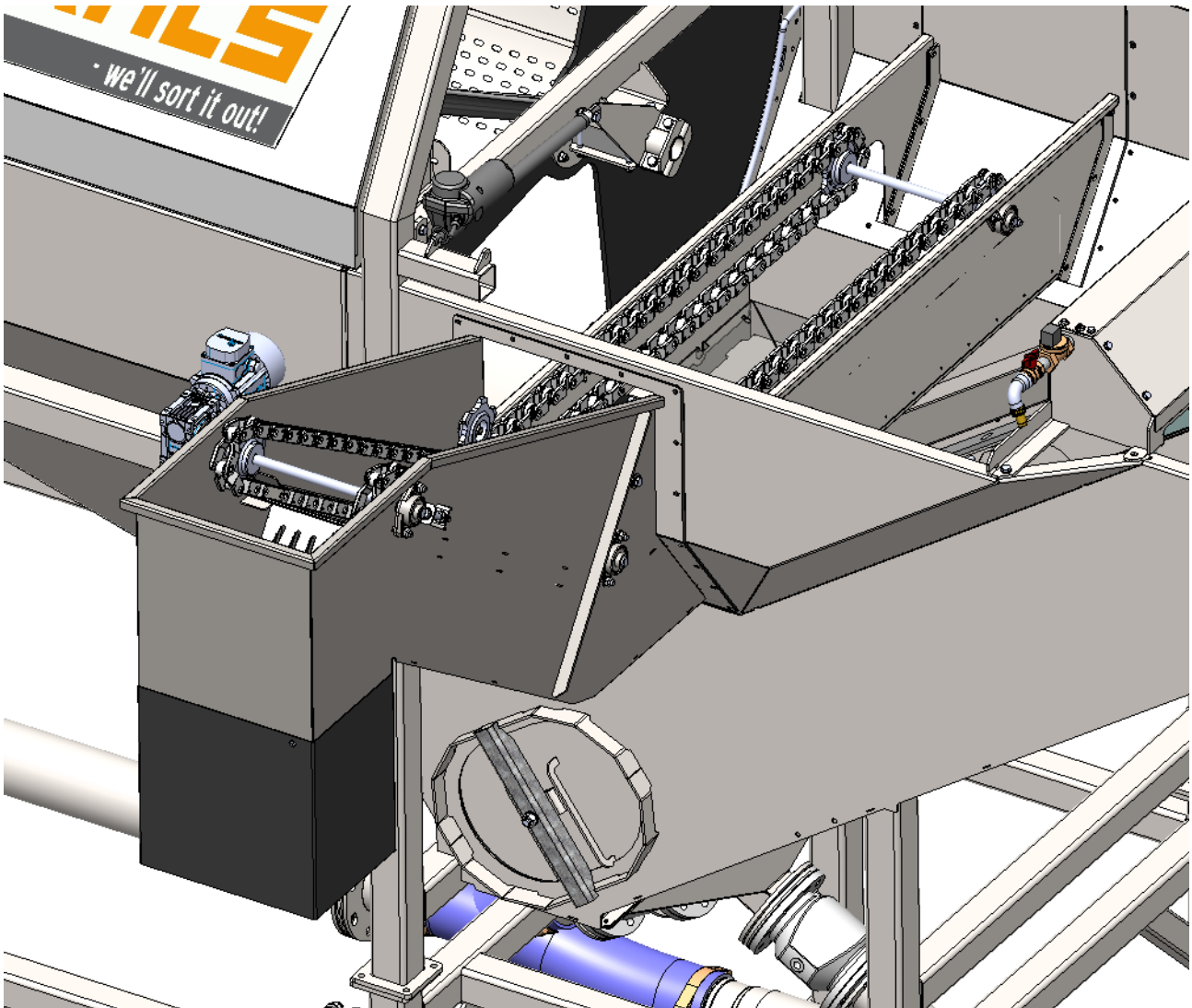

## 5.2 Internal sprinkling

Carrots are washed at low water level and sprinkling in the washing barrel.

Water for internal sprinkling must be pumped from the outlet section by a pump unit.

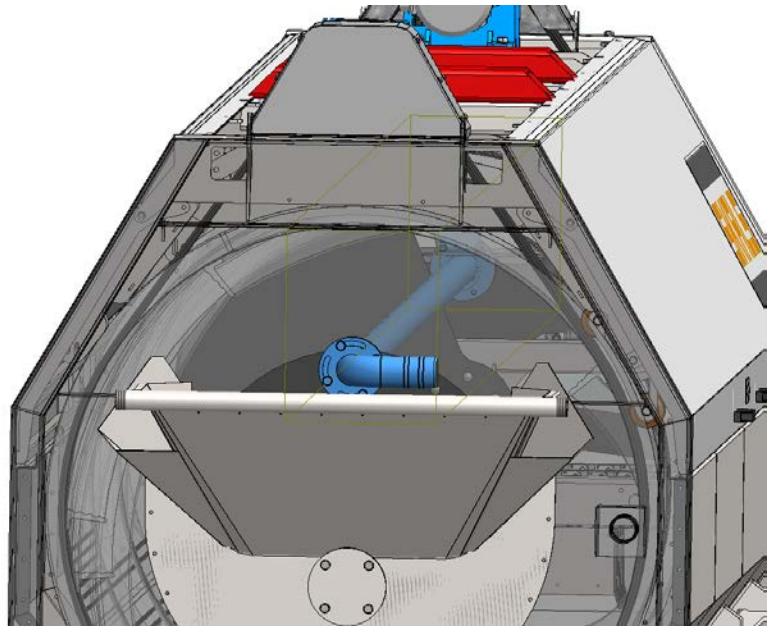

## 6 Before operation

Before operation the machine must be checked for damages that has occurred during transport.

Damages and defects must be reported to the manufacturer.

### 6.1 Installation

It is important that the machine is placed on level ground, to obtain optimal operation and long machine life.

The machine is placed on its support frame and is fitted with enclosed M12x40 bolts.

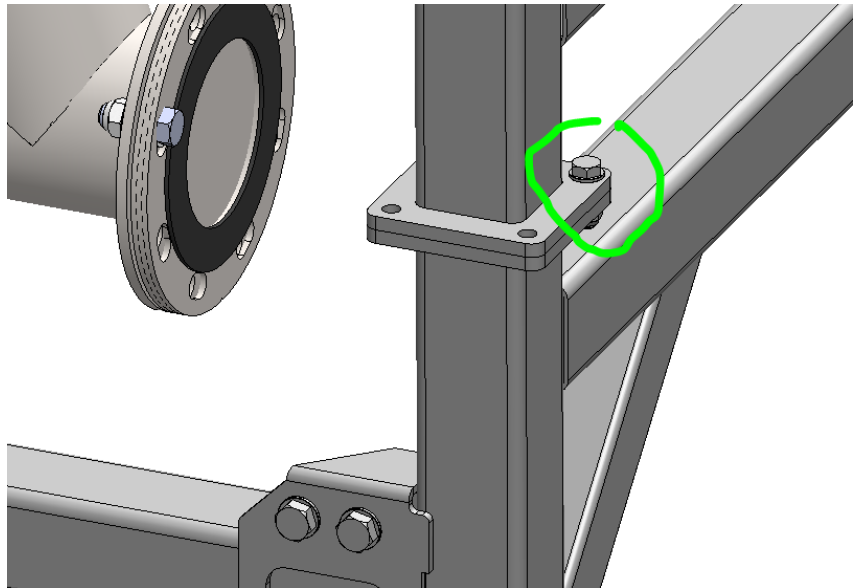

The funnel under the outlet must be mounted with M8 bolts and a gasket.

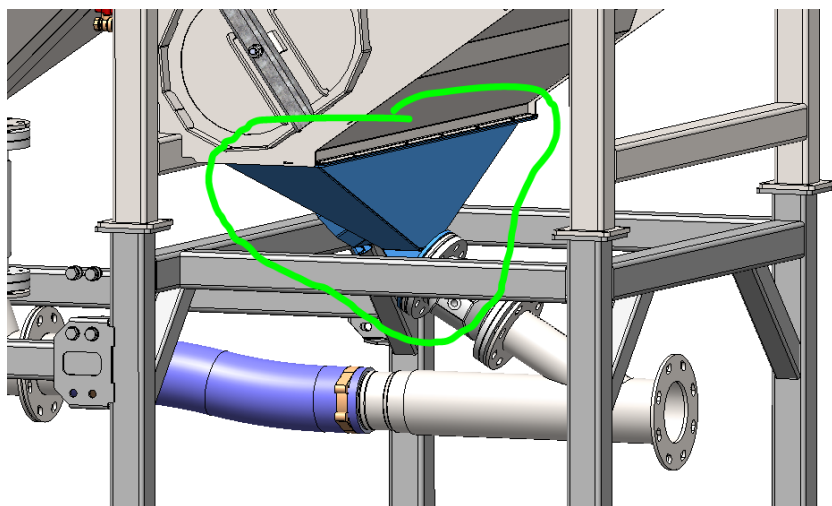

## 6.2 Electrical connection

Electrical connection has to be performed according to national legislation.

### **As standard 3 Fase 400V + N + PE**

(The machine can be prepared for 3x230V + PE)

Control cabinet must be placed where no direct water spray occur.

## 6.3 Air pressure connection

Pinch valves for bottom outlet are activated by air pressure. The pressure regulator in the pneumatic control cabinet is preset at 3 bar.

The pneumatic cabinet must be connected to a compressor delivering minimum 5 bar and 20 litres/min.

The air consumption is depending on the water flow to the washer and on the lowering level when opening. (increased lowering level = less valve activations)

## 7 Control and operation

### 7.1 General

Operation and settings are controlled from the touch panel.  
All errors and warnings are shown on the display as well.

### 7.2 Main screen

At power up the MAIN SCREEN is shown with a pop-up message showing that the emergency circuit must be reset. The emergency circuit is always broken at power up or if the emergency button has been activated.

Check that buttons are released and press "RESET EMERGENCY STOP".



When the emergency circuit is OK the pop-up disappears and the MAIN SCREEN is shown.

From the MAIN SCREEN the wanted function can be chosen.

**RUN WASH:** If the machine is supplied with water and ready to run.

If water is missing, this will be shown in the status field.

**FILL WATER:** With a pump or magnet valve installed to fill the washer with fresh water, FILL WATER is an automatic function for filling the washer to a predefined level.

After filling the status field will show READY TO RUN



**EMPTYING:** Is used after normal operation to open the outlet damper, and let the machine run for a predefined time until its empty. The time can be set under SETUP

**CLEANING:** Is for running the machine during cleaning.

### 7.3 Settings for WASH

Pressing SETUP-button enters the SETUP-menu.



The SETUP-menu gives access to all settings. Press LEFT or RIGHT arrow to browse the menu. First page gives setup values for water levels during normal operation and filling.

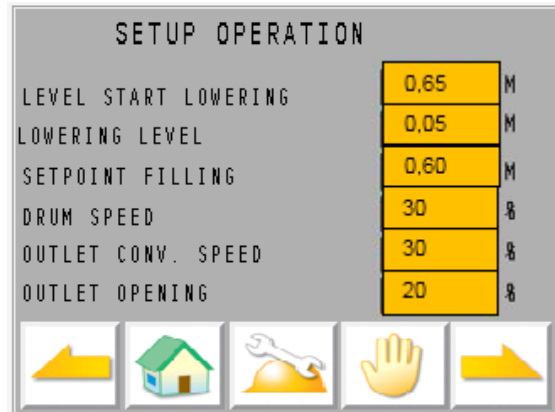

#### LEVEL START LOWERING:

This level controls when sludge is let out of the bottom valves. The water level always increases slowly due to sprinkling or faster if additional water is added. When the water reaches this level, the next valve in the cycle opens.

Normal setting is 0.65m

#### LOWERING LEVEL

Is the level measured in meter that the water level must decrease before the valve closes again.

Normal setting is 0,03-0,05m

#### SETPOINT FILLING:

The filling function fills the washer up to this level.

Normal setting is a little below LEVEL START LOWERING

#### DRUM SPEED:

Gives the speed that the drum is running during normal operation.

Normal setting is 30%

#### OUTLET CONV. SPEED:

Indicates the outfeed conveyor speed during normal operation.

Normal setting: 30%

#### OUTLET OPENING:

This parameter determines the opening of the outlet damper in %.

Higher value = increase damper opening = less washing of the vegetables.

Lower value = decrease damper opening = increase washing time in the barrel

Press NEXT to show settings page 2.



**CONV FLOATINGS RUNTIME / PAUSE:**

Determines run/pause interval for the floatings conveyor (Optional)

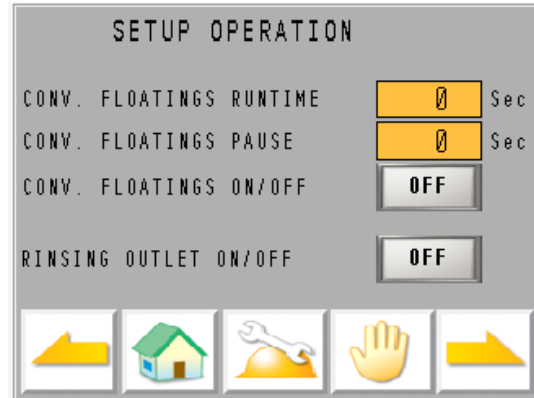

**CONV. FLOATINGS ON/OFF**

Conveyor cycle can be ON or OFF

**RINSING OUTLET ON/OFF:**

Rinsing of products on the outlet conveyor can be ON or OFF.

Press NEXT to show settings page 3.



Page 3 determines settings for sludge outlet logistics.

The bigger washers can have up to 6 bottom valves.

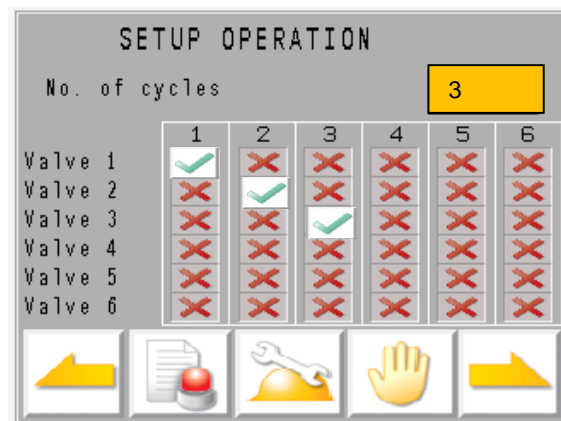

If the washer has 3 bottom valves it is per definition valve 1, 2 and 3.

One cycle is defined by one valve opens and closes.

You can choose the number of cycles. And you can choose the valve or valves that must open during the cycle. If more valves are chosen for one cycle, the flow from each valve is reduced.



Press NEXT to show settings for emptying.



### AFTERRUN EMPTYING

When selecting the emptying function it takes some minutes before all vegetables has left the washer.

This parameter determines the time of the emptying cycle. The machine stops after timer runout.

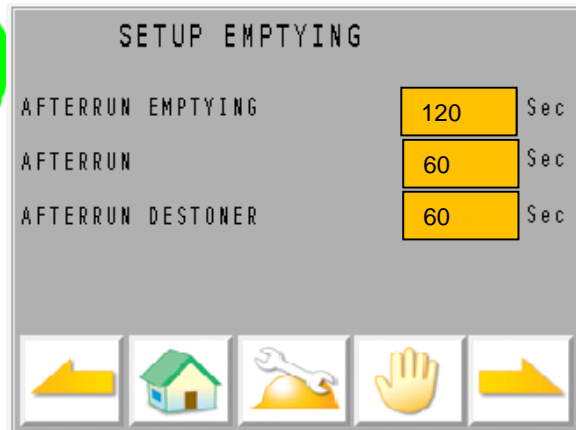

### AFTERRUN:

Afterrun at normal stop can partly empty the machine before the emptying function is selected.

### AFTERRUN DESTONER: (OPTIONAL)

Is for afterrun when a destoner pump is connected. Afterrun secures that the destoner is empty for products before it stops.

Press NEXT to show settings for cleaning.



During cleaning, the speed of the barrel and outfeed conveyor can be set.



## 7.4 Overview

Press PREVIOUS from the main screen.



The screen gives an overview of all machine functions.

Motors and valves are represented by an indicator showing green light when the function is active.

A list shows actual values and settings for the water-logistics.

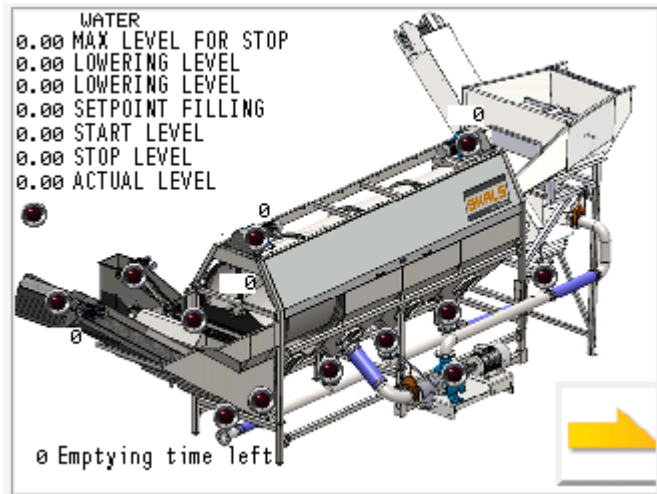



## 7.7 Language settings – from the settings menu

Press SETUP again when you are inside the SETUP MENU.



LANGUAGE can be selected by pressing the relevant FLAG

- Danish
- English
- German
- Russian



## 8 Service and maintenance

During service the main service breaker must be OFF and locked.

### 8.1 Bearings

The bearings on the outfeed conveyor are operating under water and are therefore water proof. The bearings must be lubricated with a food suitable bearing grease as Rocol Foodlube Universal Grease 2.

Lubrication interval is approx. 500 hrs.  
The bearings must be lubricated with 2-4 pushes on a normal manual grease gun.

Grease nipples are placed on both sides of the conveyor as shown.

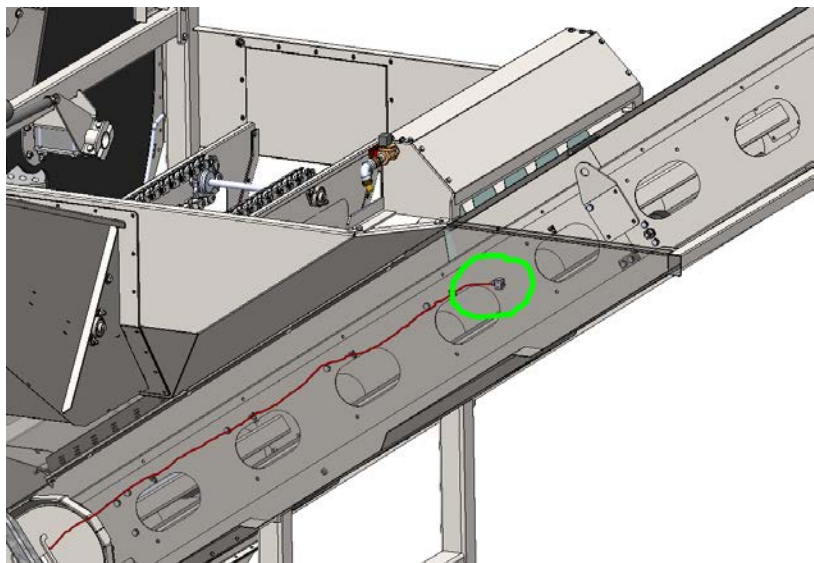

Other bearings are lubricated for life and requires no further maintenance.

### 8.2 Gearbox

Gearbox for washer drum and conveyors are lubricated for life and requires no oil exchange.

The Oil level can be checked, but if there is no leakage signs, there is no reason for refill.

### 8.3 Conveyor belts

The machine is installed with food suitable PVC belt or a pintle belt. Both types must be checked and adjusted on regular basis, to ensure long life.

Belts that has not been adjusted correctly are not covered by warranty.

## 8.4 Cleaning

At high pressure water cleaning, following areas must not be sprayed on directly:

Bearings, gear motors, electric control cabinet and pneumatic control cabinet.

Regular maintenance and cleaning is important for achieving high availability, long machine life and low service cost.

## 9 Transport

Eyes for lifting on top of the machine must be used when lifting by crane.

**Attention:**  
Do never walk underneath a hanging load.

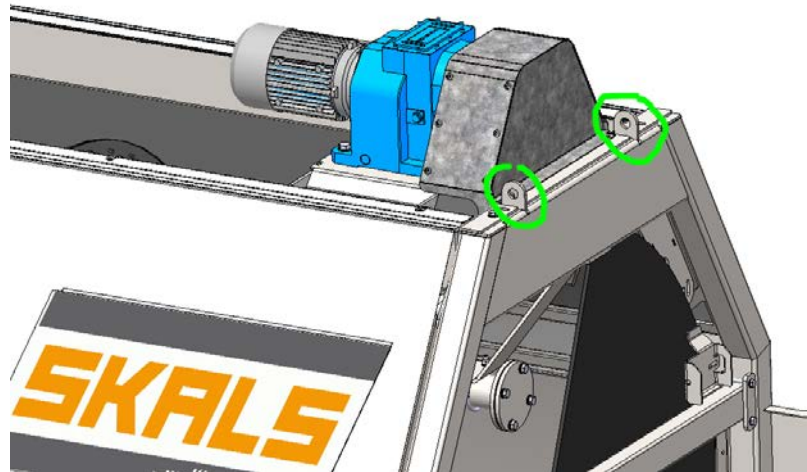

## 10 Specifications

The SKALS VTX washing machine is available in various sizes and with various options. Specifications below regarding capacity are guiding values.

<b>Model</b>	<b>Moduler</b>	<b>Dimensioner</b>	<b>Kapacitet kartofler</b>	<b>Kapacitet gulerødder</b>	<b>Effekt</b>
VTX 1425	2	Ø1400x2500	20	13	3kW
VTX1437	3	Ø1400x3750	30	20	4kW
VTX1450	4	Ø1400x5000	40	27	2x3kW

## 11 Spare parts

When ordering spare parts, please inform regarding machine type, serial no. and spare part no. according to illustrations below.

Transmission:

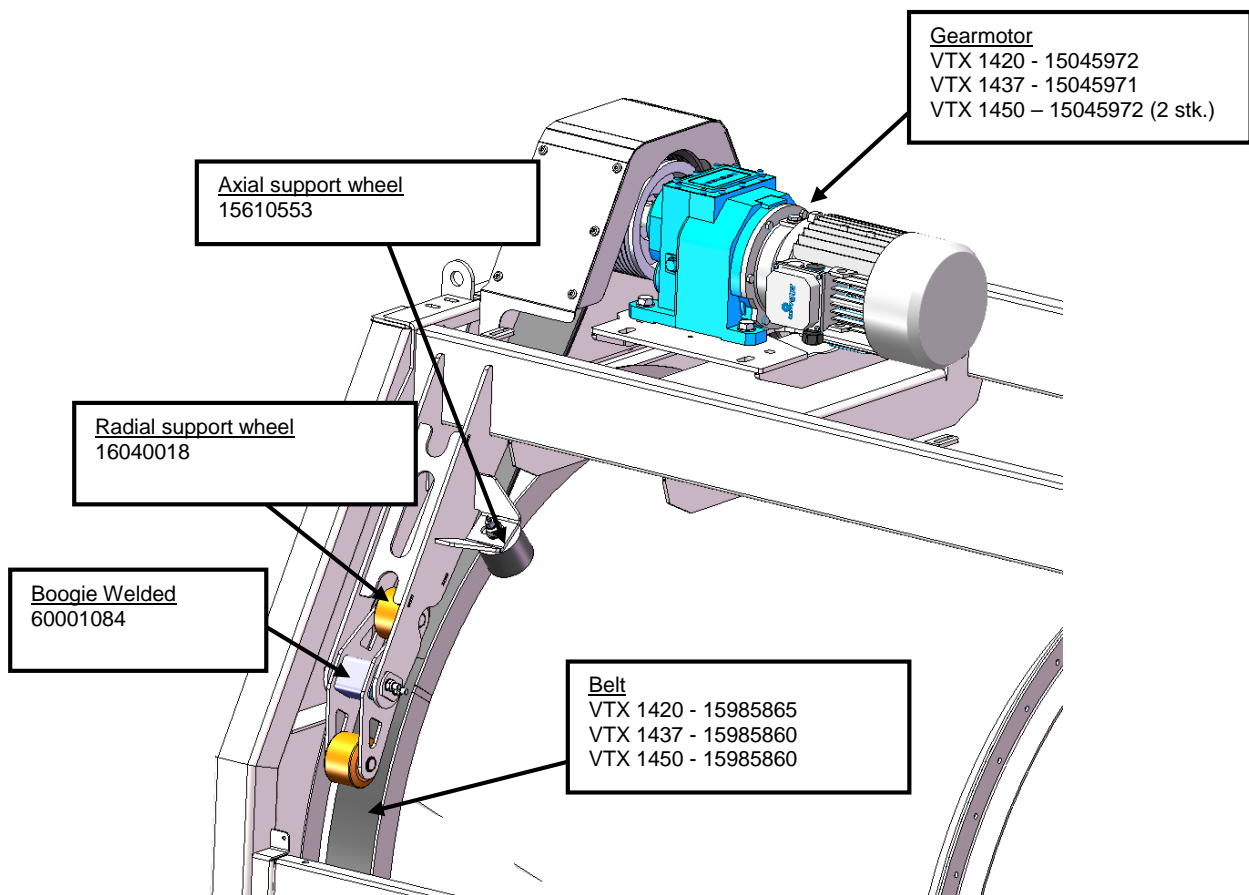



Outlet:

Linak Actuator  
15230575

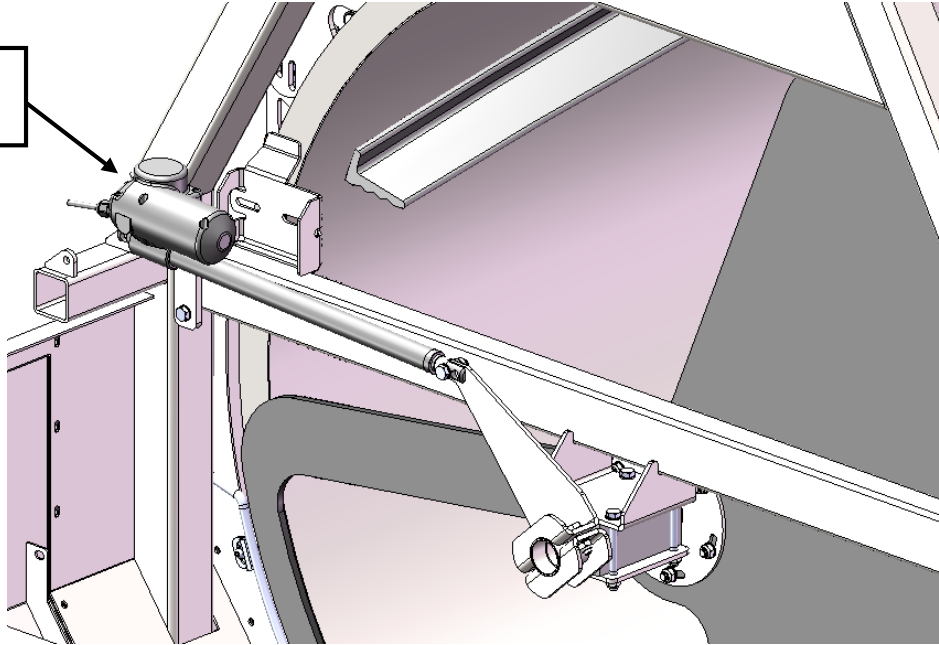

Bottom valves and pressure transmitter:

Pressure Transmitter  
10024995

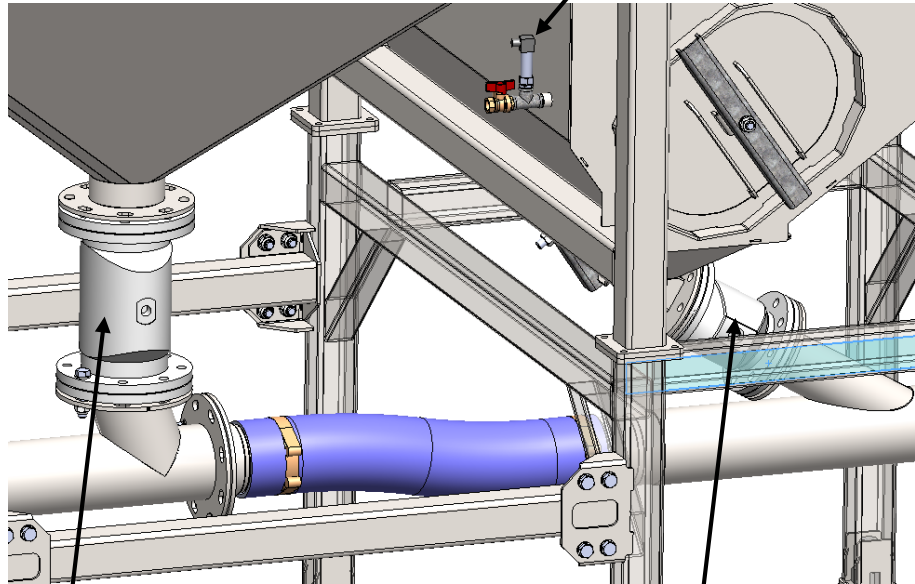

Pneumatic pinch Valve DN125  
15786000  
Hose f. pneumatic pinch valve  
15786001

Pneumatic pinch Valve DN80  
15786010  
Hose f. pneumatic pinch valve  
15786011

Outlet conveyor (PVC belt ):

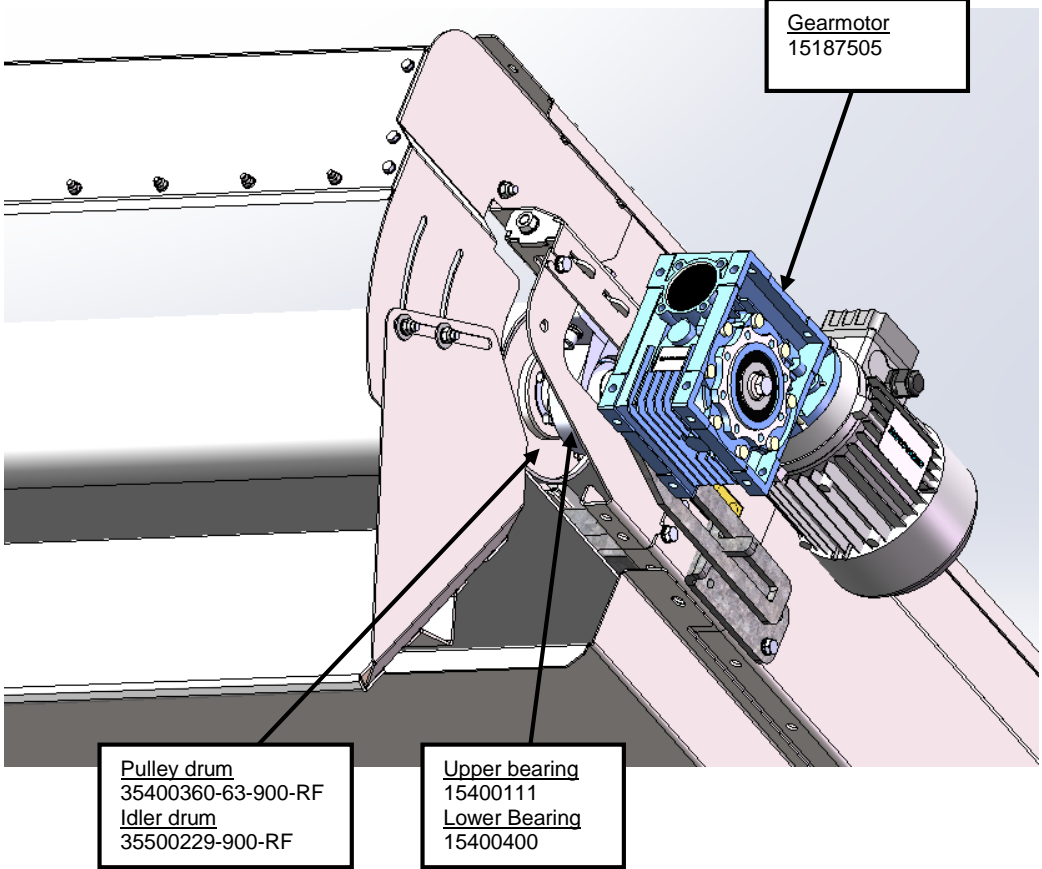

## 12 Electric wiring diagram (valid for 3x400V +N +PE)

See attachment

## 13 EU Declaration of Conformity

<b>Manufacturer</b>	
Company name:	A/S Skals Maskinfabrik
Address:	Hovedgaden 56
	DK-8832 Skals, Denmark
Telephone:	+45 87 25 62 00

hereby declares that

<b>Machine:</b>	<b>Weighing machine</b>
Brand:	<b>AMV1</b>
Type, serial no., year:	

Has been manufactured in conformity with the:

- 1 Machinery Directive 2006/42/EC
- 2 Low Voltage Directive (LVD) 2006/95/EC
- 3 Electromagnetic Compatibility (EMC) Directive 89/336/EEC and the amended 93/68/EEC.

<b>Title:</b>	Production Manager
Name:	Søren Lund Madsen
Company:	A/S Skals Maskinfabrik

Date: \_\_\_\_\_

Signature: \_\_\_\_\_

